

WARMTECH WT01 INSTRUCTIONS



ENGLISH

CONTENTS

Illustrations	3	Instructions	8
Figure 1		Figure 1 - Content	
Figure 2		Figure 2 - Warning: Important Safety Instructions	
Figure 3		Figure 3 - Thermostat Placement	
Figure 4		Figure 4 - Opening the Thermostat	
Figure 5		Figure 5 - Connections	
Figure 6		Figure 6 & 7 - Mounting the Thermostat	
Figure 7		Figure 8 - Operating the Thermostat	
Figure 8		Figure 9 - Troubleshooting	
Figure 9		Technical Data	
		Warranty	
		Customer Assistance	

FIG. 1

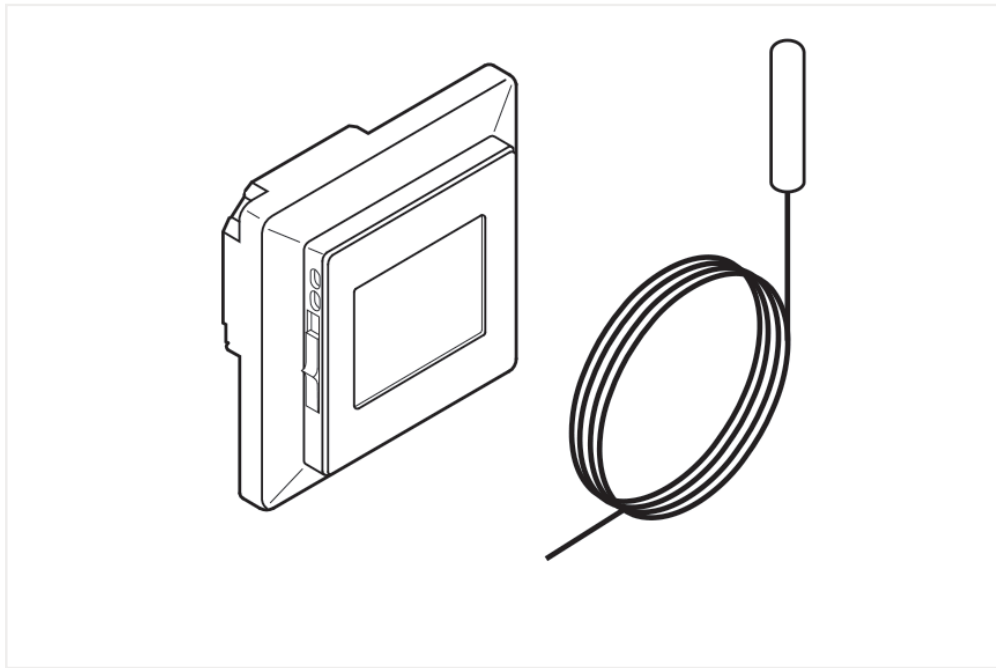

BR1017A01

FIG. 2

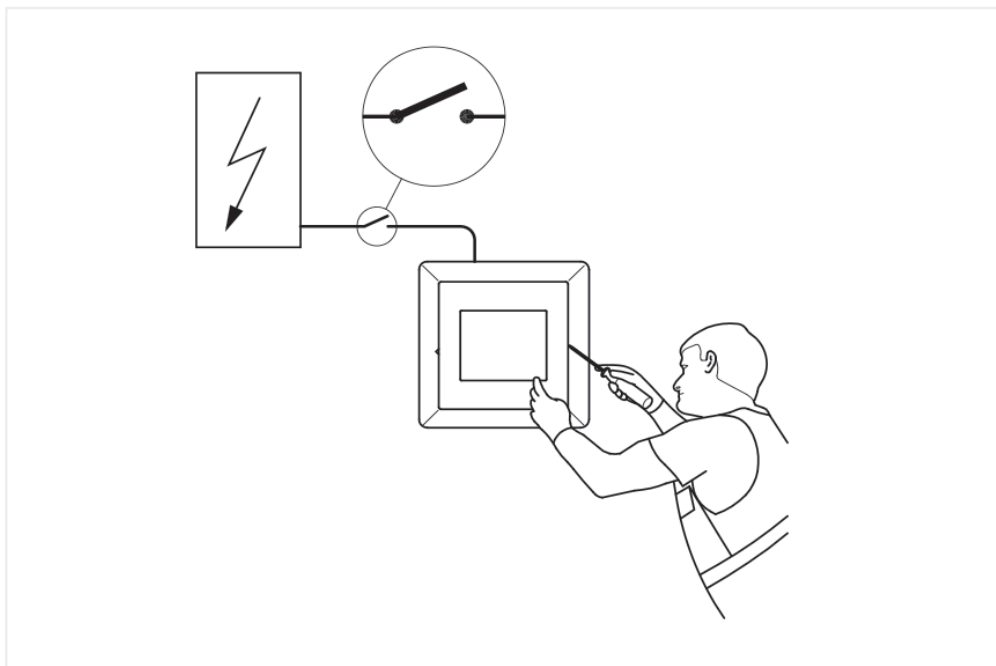

BR1017A02

FIG. 3

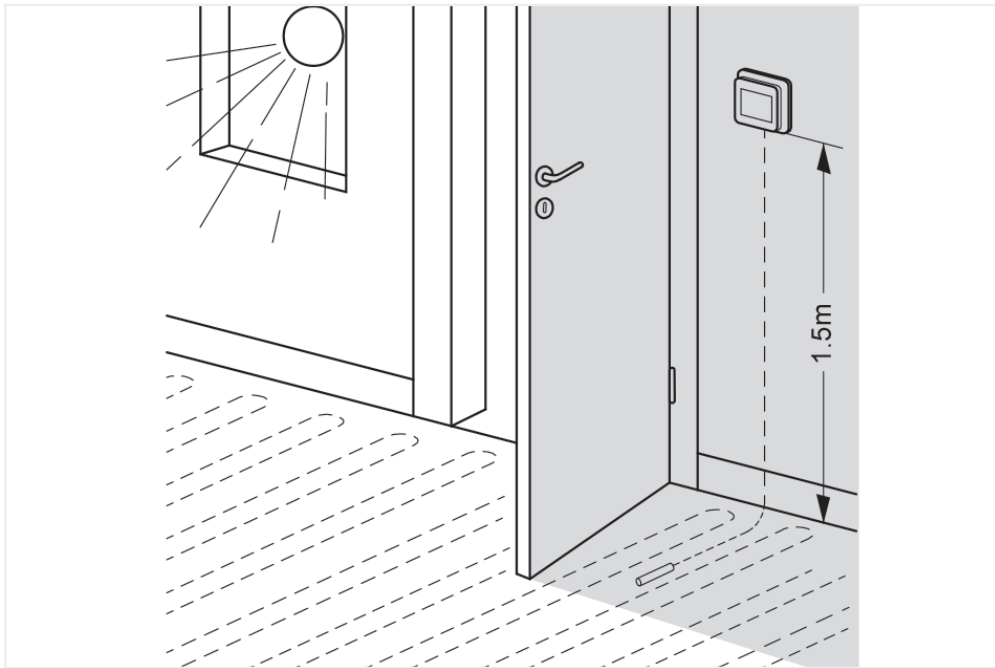

BR1017A03A

FIG. 4

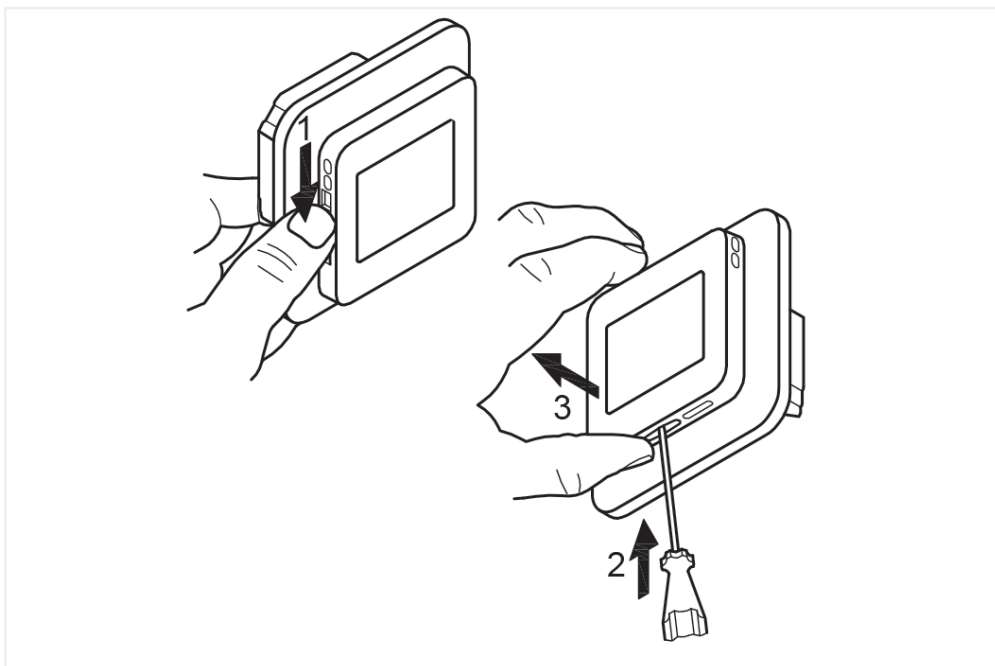

BR1017A04C

FIG. 5

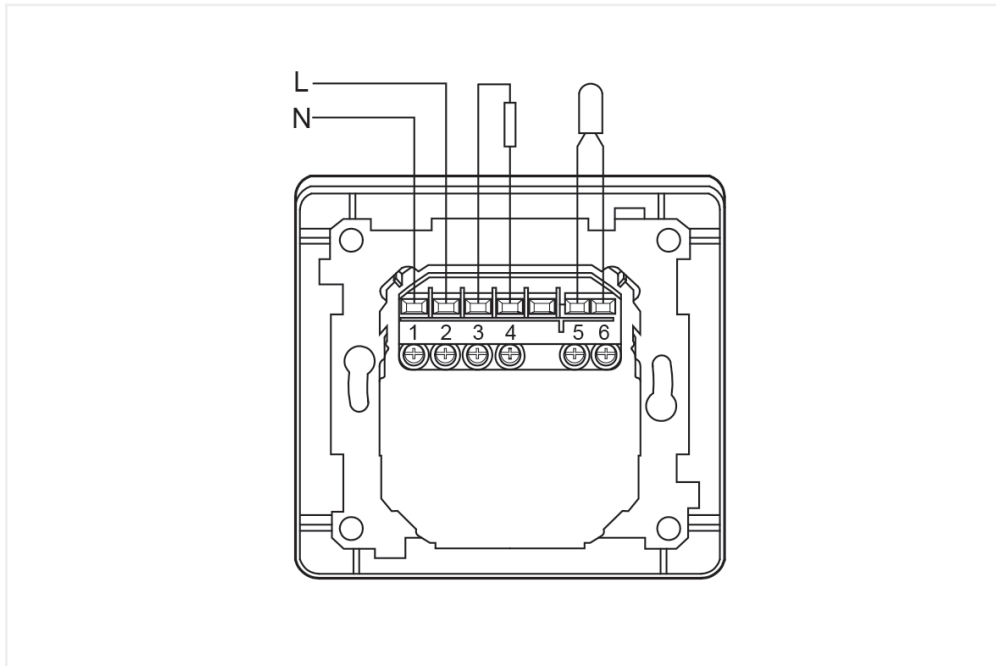

BR1017A05A

FIG. 6

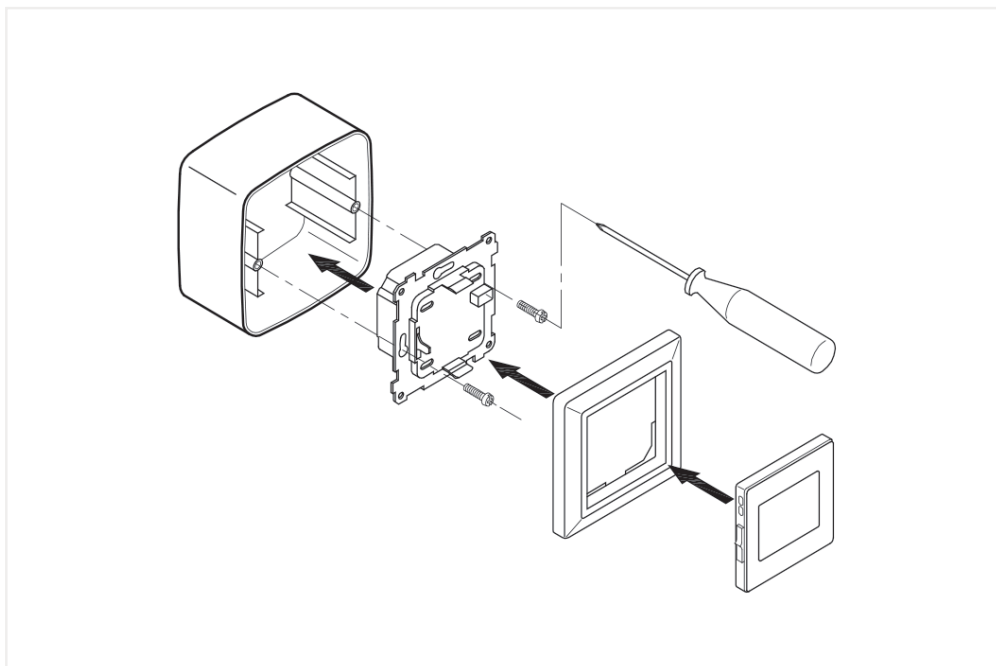

BR1017A06

FIG. 7

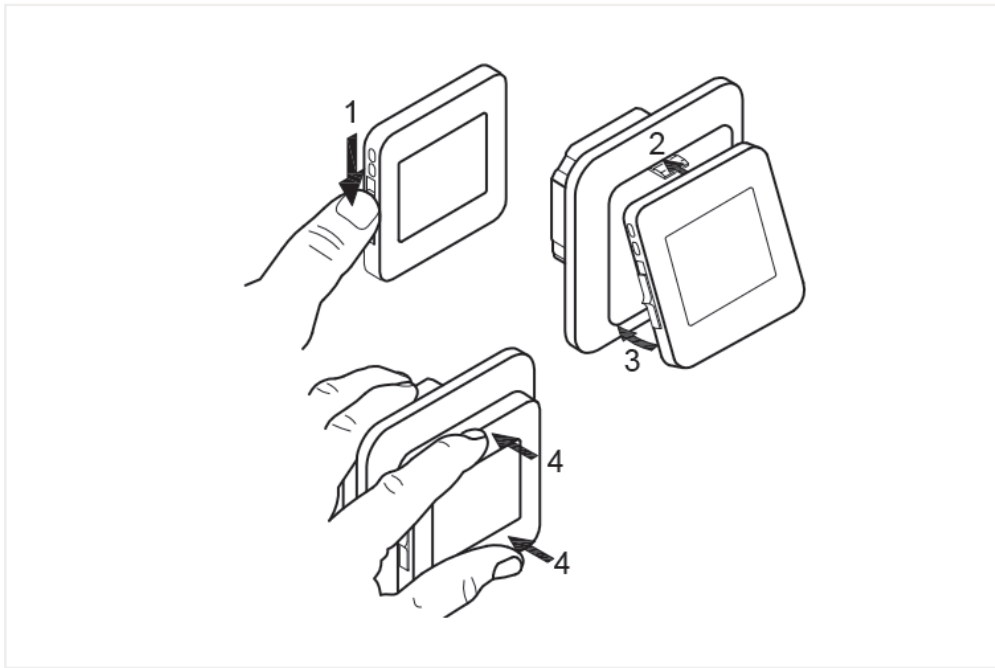

BR1017A14

FIG. 8

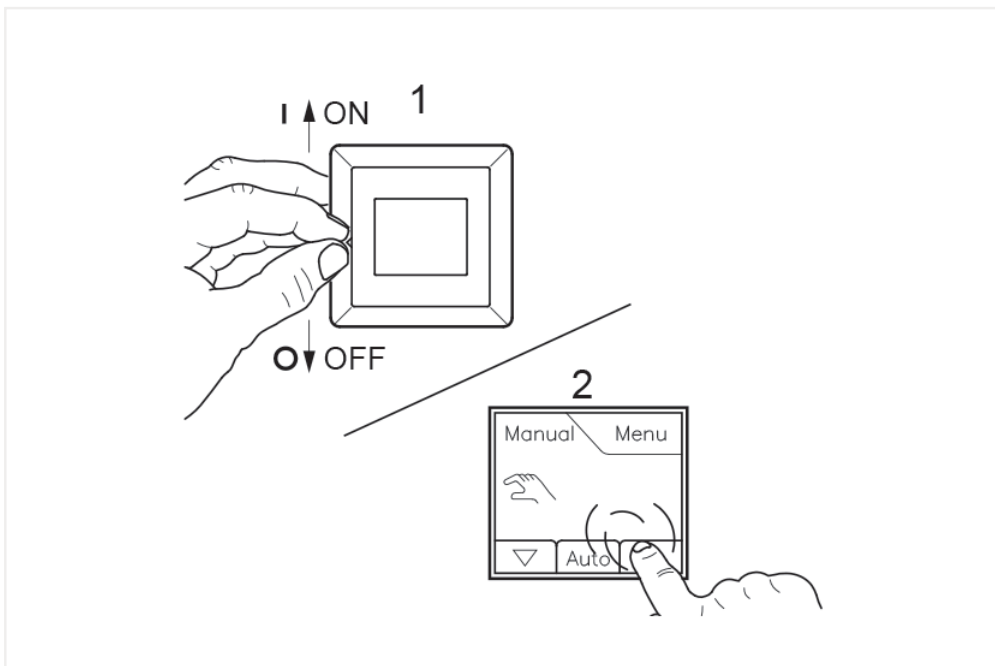

BR1017A07

FIG. 9

NTC 12kΩ @ 25°Celsius		
°Celsius	°Fahrenheit	Ohm (Ω)
-10°C	14°F	55076 Ω
0°C	32°F	34603 Ω
10°C	50°F	22284 Ω
20°C	68°F	14675 Ω
30°C	86°F	9860 Ω

BR1017A17

FIG. 1 - CONTENT

- Thermostat
- Sensor

The thermostat is an electronic PWM/PI thermostat for temperature control by means of an NTC sensor located either externally or internally within the thermostat.

The thermostat is for flush mounting in a wall socket. A baseplate for wall mounting is also available.

Product programme

WT01 Clock-thermostat with two sensors:
floor sensor and built-in room sensor.

FIG. 2 – WARNING: IMPORTANT SAFETY INSTRUCTIONS

Disconnect the power supply before carrying out any installation or maintenance work on this thermostat and associated components. The thermostat and associated components should only be installed by a competent person (i.e. a qualified electrician). Electrical installation must be in accordance with appropriate statutory regulations.

FIG. 3 – THERMOSTAT PLACEMENT

Mounting of sensor

The floor sensor contains a safety extra-low voltage (SELV) circuit, allowing it to be placed as close to the floor surface as possible without having to take account of the risk of shock should the sensor cable become damaged. The two wires connecting the sensor to the mounting box must be additionally insulated, e.g. shrink flex.

To prevent loose wires in the fixed installation from coming into contact with the terminal block for the floor sensor, they must be restrained using cable ties.

It is strongly recommended that the cable and sensor are placed in a non-conductive installation pipe embedded in the floor. The end of the pipe must be sealed and the pipe placed as high as possible in the concrete layer. Alternatively, the sensor can be embedded directly in the floor. The sensor cable must be led through a separate conduit or segregated from power cables.

The floor sensor must be centred between loops of heating cable. The sensor cable may be extended up to 100 m by means of a separate two-core cable. Two vacant wires in a multi-core cable used, for example, to supply current to the floor heating cable must not be used. The switching peaks of such current supply lines may create interference signals that prevent optimum thermostat function.

If a shielded cable is used, the shield must not be connected to earth (PE). The two-core cable must be placed in a separate pipe or segregated from power cables in some other way.

Mounting of thermostat with built-in sensor

The room sensor is used for comfort temperature regulation in rooms. The thermostat should be mounted on the wall approx. 1.5 m above the floor in such a way as to allow free air circulation around it. Draughts and direct sunlight or other heat sources must be avoided.

FIG. 4 – OPENING THE THERMOSTAT

1. Slide the power button down to Off "0".
2. Release the front cover ONLY by inserting a small screwdriver into the slot at the centre of the bottom side of the front cover to press and hold the catch securing the front cover.
3. Then carefully pull the front cover away, initially from the lower part of the thermostat, then from the upper part of the thermostat.

FIG. 5 – CONNECTIONS

Connect the wires in accordance with the diagram. The wires must be connected as follows:

- Term. 1: Neutral (N)
- Term. 2: Live (L)
- Term. 3-4: Output, max. 16 A
- Term. X: Do not connect
- Term. 5-6: External floor sensor

FIG. 6&7 – MOUNTING THE THERMOSTAT

1. Mount the thermostat in the wall socket.
2. Fit the frame and carefully press the cover onto the thermostat — starting with the upper part of the cover, then the lower part of the cover. Ensure that both the power slide button on the cover and the power switch pin in the thermostat are down.
3. Click the cover into place by applying light, even pressure.

Warning! Do not apply pressure to the corners of the display cover or to the display itself.

DO NOT open the thermostat by releasing the four fixing clips on the back.

FIG. 8 – OPERATING THE THERMOSTAT

There is an ON/OFF switch on the left side of the thermostat: UP = ON and DOWN = OFF.

The resistive touchscreen requires a soft tap with your fingertip to register the touch.

Installer Wizzard

The first time the thermostat is connected, push the power slide button to On “I” The Installer Wizard on the touchscreen will guide you through the set up of:

1. Region
2. Language
3. Date
4. Time
5. Floor Type

FIG. 9 – TROUBLESHOOTING

If the sensor is disconnected or short-circuited, the heating system is switched off. The sensor can be checked against the resistance table.

Error codes

E0: Internal fault. The thermostat must be replaced.

E1: Built-in sensor defective or short-circuited. Replace the thermostat, or use the floor sensor only.

E2: External sensor disconnected, defective or short-circuited. Reconnect the sensor if disconnected, or replace the sensor.

E5: Internal overheating. Inspect the installation.

CE marking

According to the following standard: LVD/EMC: EN 60730-2-9

Classification

Protection from electric shock must be assured by appropriate installation. Appropriate installation must meet the requirements of Class II (enhanced insulation).

Environment and recycling

Please help us to protect the environment by disposing of the packaging in accordance with national regulations for waste processing.

Recycling of obsolete appliances



Appliances with this label must not be disposed of with general household waste. They must be collected separately and disposed of in compliance with local regulations.

TECHNICAL DATA

Voltage	100-240 VAC	Software class	A
Max. pre-fuse	16 A	TB	125°C
Built-in circuit breaker	2-pole, 16 A	ELV limits realized	SELV 24 V
Output relay	make contact - SPST - NO	Pollution degree rating	2
Output	max. 16 A	Rated impulse voltage	4 kV
Terminal wire size	1.5-2.5 mm ²	Enclosure rating	IP 21
Control principle	PWM/PI	Dimensions	H/115, W/84, D/40 mm
Standby power	0.5 W	Build-in depth	23 mm
Battery backup	5 years	Display	176x220 pixel TFT - resistive touch
Action type	1.B	EU registered design	DM/082270

The thermostat is maintenance free.

WARRANTY

Twelve (12) Month Warranty

This product is warranted against defects in material and workmanship under normal conditions of use for a period of twelve months from the date of purchase. During this period, Warmtech will repair or replace the product, if it is defective in normal operating conditions in terms of materials or workmanship, with a new product of equivalent quality at Warmtech's option. The warranty does not cover costs of transportation, removal, installation or damage caused by misuse or accident. In no event will Warmtech be liable for consequential loss resulting from the installation of the product.

Any defective product should be sent with the original invoice to the original installer, or shipped prepaid, insured and sent to Warmtech.

Customer Assistance

Phone: 1300 138 126

Email: info@warmtech.com.au

Website: www.warmtech.com.au